

INSTRUCTION MANUAL

R88000
T88000
(including ATEX)



**Factory set transmitters are ready to use.
Connect according the labels.
Otherwise follow the calibration instructions.**

Input signals

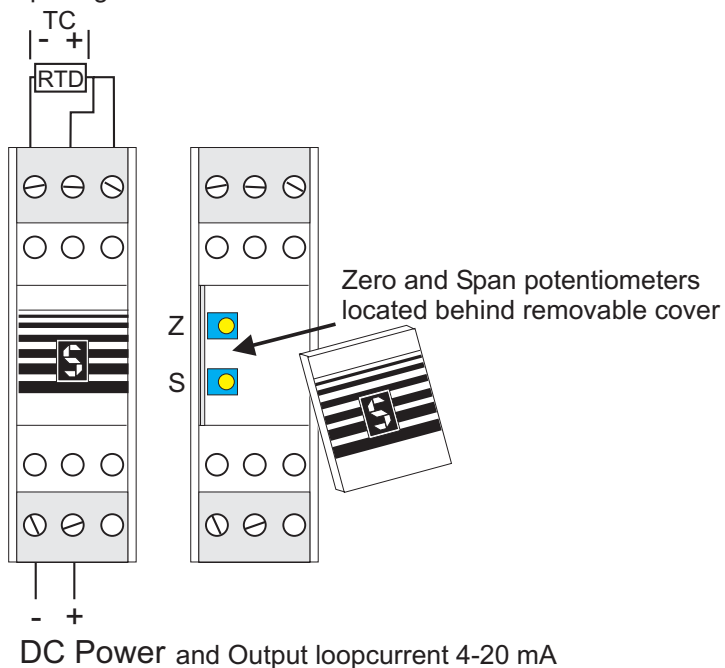

CONTENTS:

- 2 Dimensions
- 3 Specifications
- 4 Atex & Installation requirements
- 6 Connections
- 7 Calibration Instructions

DIMENSIONS

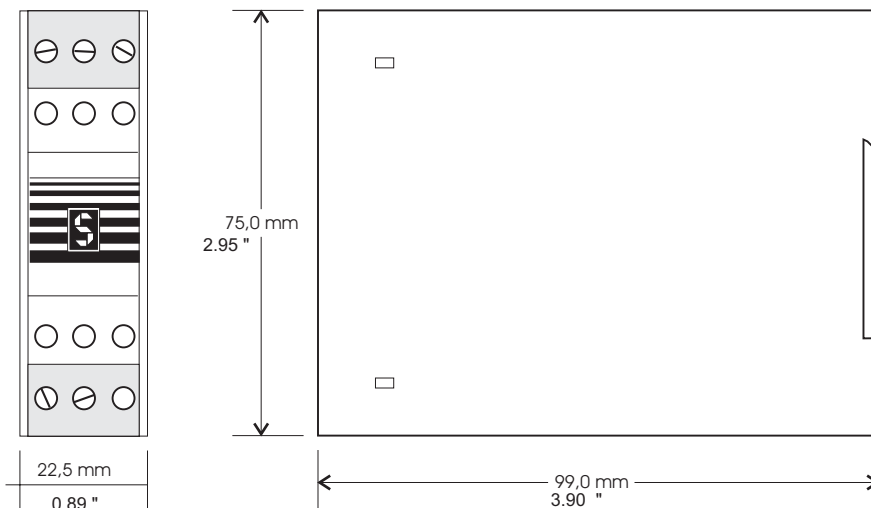

WARRANTY

Our transmitters have a 5 year warranty.
Follow usage instruction in this manual.
In case of malfunction return to your supplier.

SPECIFICATIONS

GENERAL INTRODUCTION:

The 88000 series, a family of 2-wire rail-mount transmitters, are fully scaleable and provide an industry-standard 4-20 mA output. They can be installed on a standard DIN rail. Recommended where severe conditions (temperature, vibration, etc.) prevent the use of head-mounting transmitters.

The R/T88000 series are quick and easy to scale via simple solder links.

Fine ZERO and SPAN adjustments using 20-turn precision potentiometers.

Very high load capability and polarity protection.

RTD (Pt100) units are completely linearized and thermocouple units are voltage linear.

An Intrinsically safe version is available.

Type	analog	digital	2-wire	isolated	Pt100	Tc K/J/T/E	Other Tc	HART®	ATEX
R88000	•		•		•				•
T88000	•		•			•			•
Mp88700		•	•	•	•	•	•	•	•
Mp88800		•	•		•	•			•
Mp88800R		•	•		•				•
ALM48-R	•		•		•				
ALM48-T	•		•			•			

Specifications at V_{nom} 24VDC; T_{am} 25°C and Span nom. RTD=100°C; T/C=250°C

GENERAL

Output	4-20 mA
Power supply*	12-36 VDC
Zero Drift	±0.02%/°C
Span drift	±0.02%/°C
Supply Voltage Effect	±0.01%/V
Open Circuit Detection	Upscale >23 mA, limited to 40 mA optional downscale (<2.7mA) available
Load Capability	(Vbat-12V) / 20 mA
Ambient Temp.	-20° to 80°C (-4° to 160°F)
Storage Temp.	-20° to 100°C (-4 to 210°F)
Dimensions	75mm x 22.5mm x 98.5mm (2.92" x 0.89" x 3.88")
Degree of protection	IP20

Pt100(alpha=0.00385)

Zero Adjustment

Span Adjustment

Sensor Lead Resistance Effect

Linearization

Thermocouple

Model T88000-K

Model T88000-J

Zero Adjustment

Span Adjustment

Cold Junction drift

Lead Resistance

Output

Model R88000

between -50° and +350°C (-60° and +660°F) with solder link and 20 turn Potentiometer adjustment

-50° to 800°C (90° to 1440°F) divided into 4 parts.

Scaleable via solder link inside the unit.

Fine adjustment via 20-turn Potentiometer.

0.01°C/Ohm; max. 500 Ohm

0.1%

Model T88000

Thermocouple K

Thermocouple J

0°C to 400°C (32°F to 750°F) with solder link and potentiometer

Type K 150° to 1200°C (270° to 2160°F) divided in 3 parts.

Type J 150° to 600°C (270 to 1080°F) divided in 2 parts.

0.03°C/°C

10 K Ohm max.

Voltage Linear

*NOTE:

For ATEX approved equipment the allowed power supply is limited to 30V

ATEX

GENERAL:

The R/T88000 is available in an intrinsically safe version and meets the requirements of the ATEX directive 94/9/EC.

MARKING:

All ATEX approved R/T88000 units carry the following labels:



R/T88000

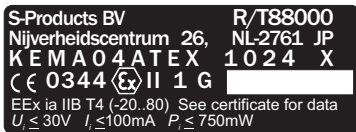

Year of production
Serial No. i.e.:

C05200

General product label

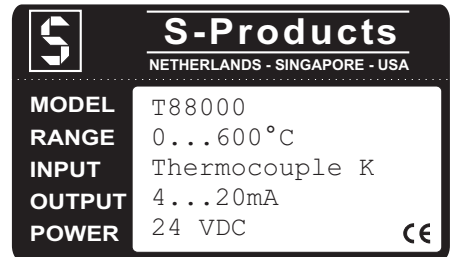

Certificate No. R/T88000 : KEMA 04ATEX 1024 X

Parameters:

Connect to a Power Supply (Zenerbarrier) with the following maximum values:

$U_o = 30$ V DC
 $I_o = 100$ mA
 $P_o = 750$ mW

CE 0344 Ex II 1 G
EEx ia IIB
T4 ($T_{amb} -20...+80^{\circ}C$)

R88000 & T88000

supply circuit KL1.A, KL1.B:

$U_i = 30$ V DC
 $I_i = 100$ mA
 $P_i = 750$ mW
 $L_i = 100$ μ H
 $C_i = 67$ nF

input circuit KL2.A, KL2.B, KL2.C:

$U_o = 30$ V DC
 $I_o = 100$ mA
 $P_o = 750$ mW
 $L_o = 14$ mH
 $C_o = 490$ nF

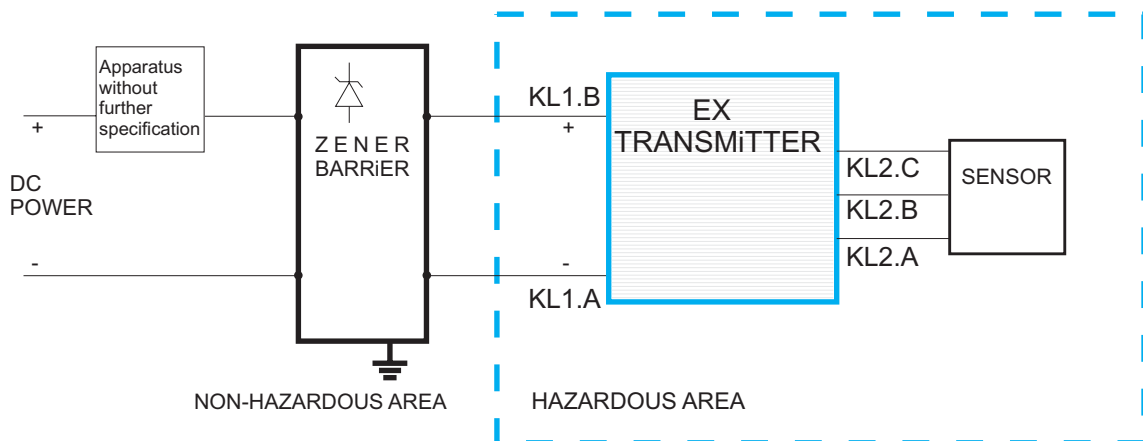

NORMATIVE REFERENCE:

The transmitters R88000 and T88000 have an EC Type examination certificate issued by KEMA and have been approved to the following standards:

EN 50014
EN 50020
EN 50284

SPECIAL CONDITIONS FOR SAFE USE:

For electrical data and temperature data see EC-Type examination certificate
KEMA 04ATEX 1024 X

INSTALLATION REQUIREMENTS

- ATEX approved equipment is only to be connected to a limited power supply (Zenerbarrier.)

The Temperature Transmitter must be mounted in an enclosure providing a degree of ingress protection of at least IP20 per EN 60529.

This enclosure must be in conformance with Clauses 4.3 and 4.4 of EN 50284, when the Temperature Transmitter is mounted in an area where the use of category 1 G apparatus is required.

This enclosure must be in conformance with Clauses 7.3 and 8.1 of EN 50014, when the Temperature Transmitter is mounted in an area where the use of category 2 G apparatus is required.

The mentioned Clauses describe how to avoid danger of ignition due to electrostatic charges.

- All 88000 series transmitters have an ingress protection of IP20.
This requires usage in a dry, clean and well controlled environment.



- Use twisted pair, shielded cable to connect the transmitter to its power supply in order to obtain the best immunity to Electromagnetic signals.

CONNECTIONS

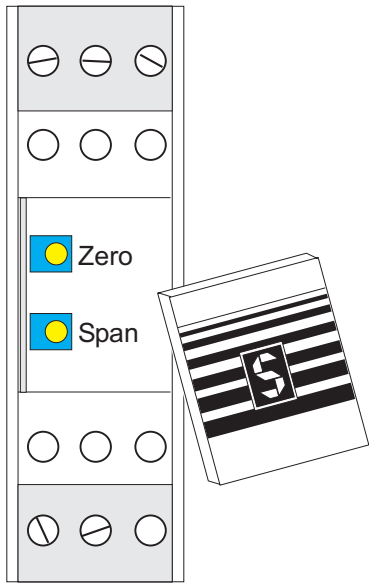

Zero and Span potentiometers located behind removable cover

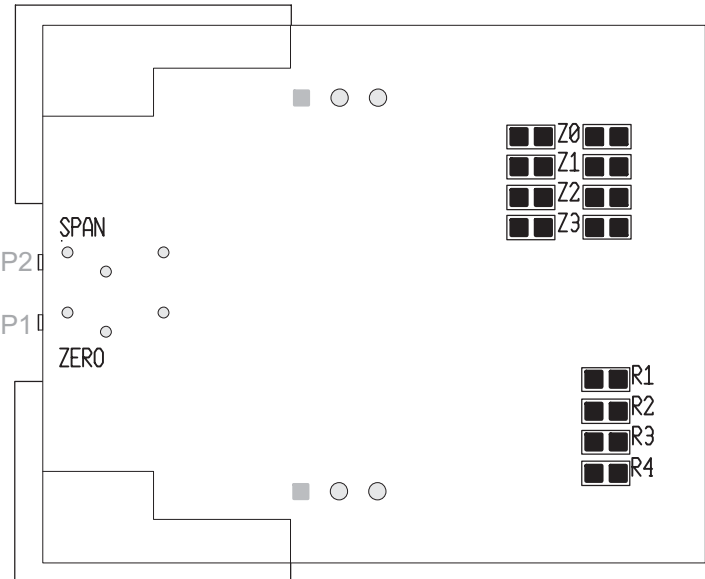
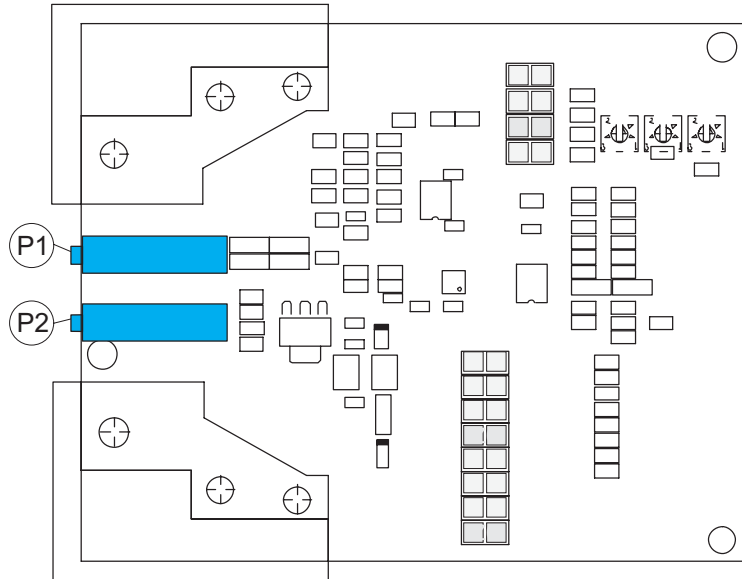

Zero selection (table 1)

LINK	RTD		K & E		J & T	
	(°C)	(°F)	(°C)	(°F)	(°C)	(°F)
Z0	-50...50	-60...125	0...100	32...200	0...100	32...200
Z1	50...150	125...300	100...200	200...400	100...200	200...400
Z2	150...250	300...500	200...300	400...575	200...300	400...575
Z3	250...350	500...600	300...400	575...750	300...400	575...750

Range selection (table 2)

LINK	RTD		K & E		J & T	
	(°C)	(°C)	(°C)	(°C)	(°C)	(°C)
R1	50...100	90...180	150...300	270...540	150...300	270...540
R2	100...200	180...360	300...600	540...1080	300...600	540...1080
R3	200...400	360...720	600...1200	1080...2160		
R4	400...800	720...1445				

INTRODUCTION

The Model 88000 is a precision 2-Wire Transmitter that provides a standard 4-20 mA signal that is directly proportional to the temperature experienced by the sensor.

The Model T88000 accepts a signal from a thermocouple. The Model R88000 is used with RTD (Pt100) sensors.

With this transmitter the following ranges are covered:

Zero selection (table 1)

LINK	RTD		K & E		J & T	
	(°C)	(°F)	(°C)	(°F)	(°C)	(°F)
Z0	-50...50	-60...125	0...100	32...200	0...100	32...200
Z1	50...150	125...300	100...200	200...400	100...200	200...400
Z2	150...250	300...500	200...300	400...575	200...300	400...575
Z3	250...350	500...600	300...400	575...750	300...400	575...750

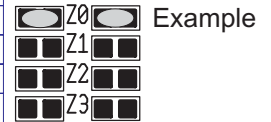

Range selection (table 2)

LINK	RTD		K & E		J & T	
	(°C)	(°F)	(°C)	(°F)	(°C)	(°F)
R1	50...100	90...180	150...300	270...540	150...300	270...540
R2	100...200	180...360	300...600	540...1080	300...600	540...1080
R3	200...400	360...720	600...1200	1080...2160		
R4	400...800	720...1445				



PROGRAMMING AND CALIBRATION INSTRUCTIONS R88000 & T88000

In order to calibrate the Model 88000, you will require the following equipment:

- A: 24V DC Power Supply with a milliamp indicator. (Model TL245 or equal)
- B: For Model R88000 units; an RTD Simulator or a precision resistance box.
For Model T88000 units; a thermocouple simulator with cold junction compensation.

1. Gently bend the sidewalls of the Model 88000 while pulling on the black terminal block.
2. Select the desired ZERO range from Table 1.
Link **both** solderlinks Z# to set the Model 88000 for the desired ZERO range.
3. Select the desired SPAN range from Table 2. Please note if, for example, 150°...+350° is required the span is 200°C, and not 350°C
Link the solderlink R# to set the Model 88000 for the desired SPAN range.
4. Connect the simulator (or resistance box) to the upper terminal strip as indicated.
Connect the power supply to the Model 88000 lower terminal block as indicated on the label.
5. Simulate the Zero input using the simulator.
Adjust the Fine ZERO Potentiometer P1 on the front of the unit to provide 4.0 mA
6. Simulate the highest input using the simulator. Adjust the Fine SPAN Potentiometer P2 on the front of the unit to obtain 20.0 mA.
7. Repeat Steps 5 and 6 to insure that both the Zero and Span are correct.
8. Remove the input simulator and power supply.
9. With the unit now calibrated, replace the printed circuit assembly into the housing.

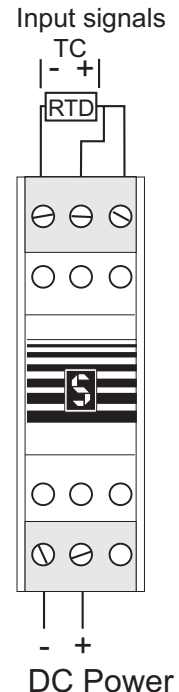

Fill in the label with a permanent marker (fibrepoint).

The Model 88000 is now **ready** to install on a standard DIN rail.

Note The solder pads on the componentside of the transmitter represent the same zero and ranges
Do **not** make solder connections on both sides.

